

Tail servo version

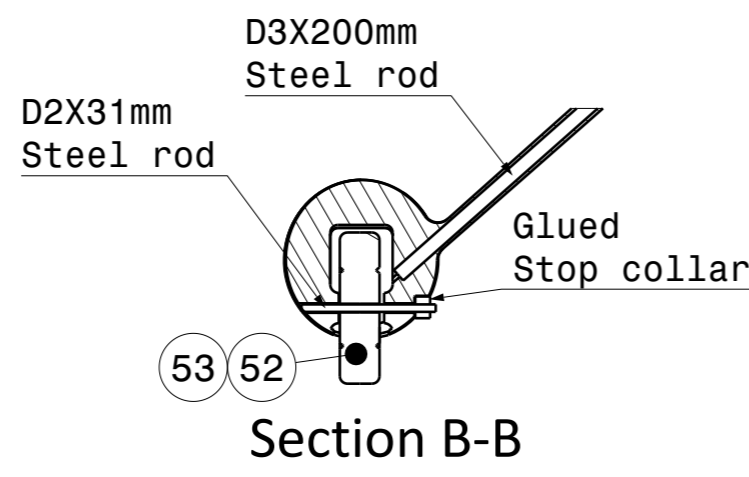

Section B-B

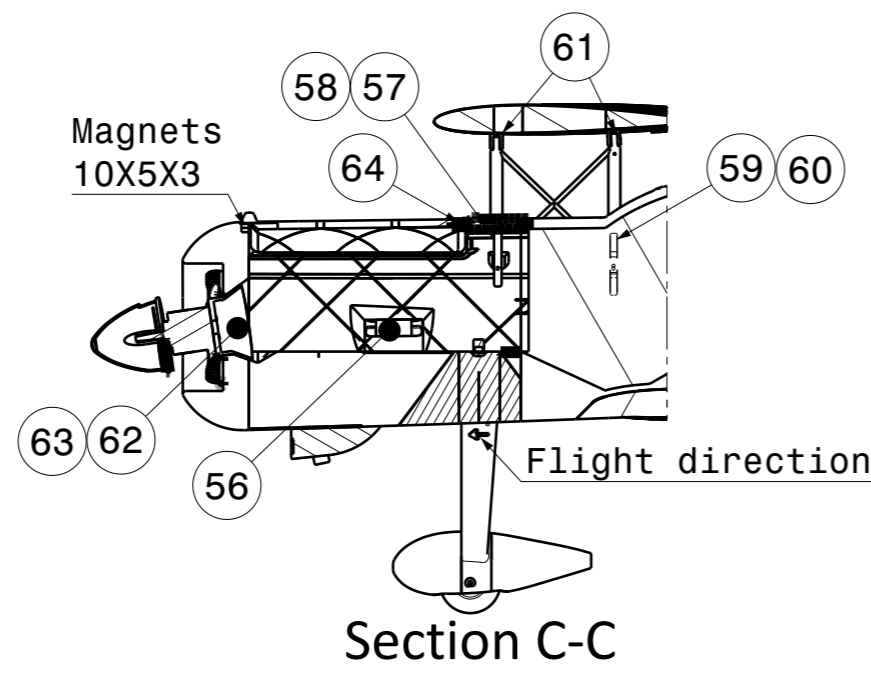

Section C-C

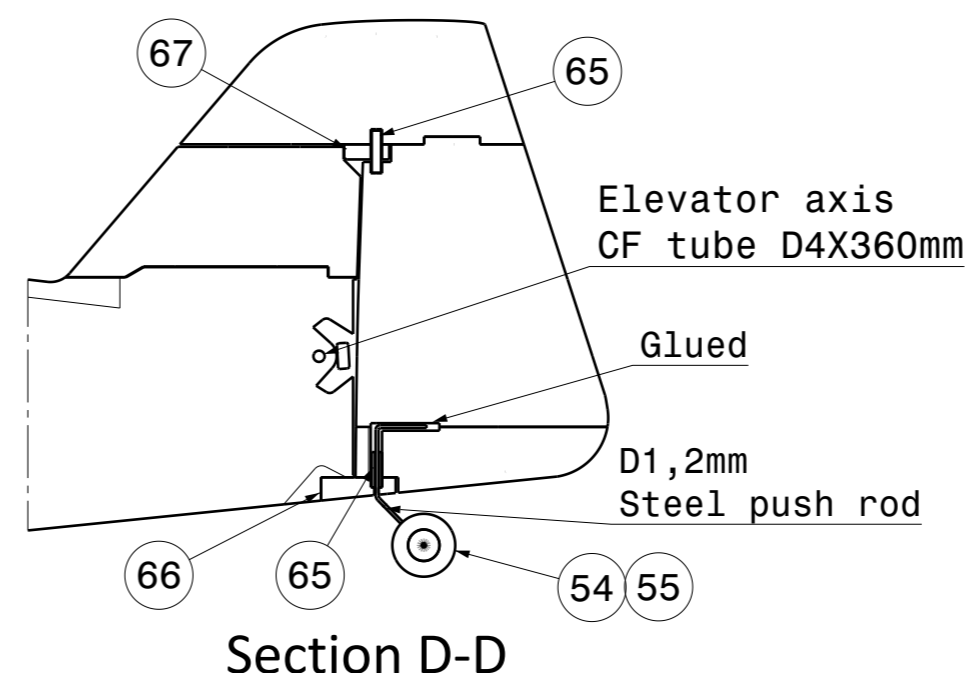

Section D-D

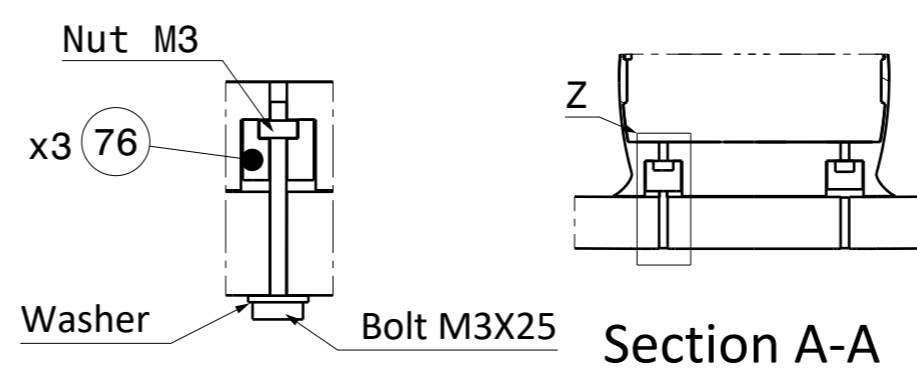

Section A-A

Detail Z
(Typical detail for interface between fuselage and wing)

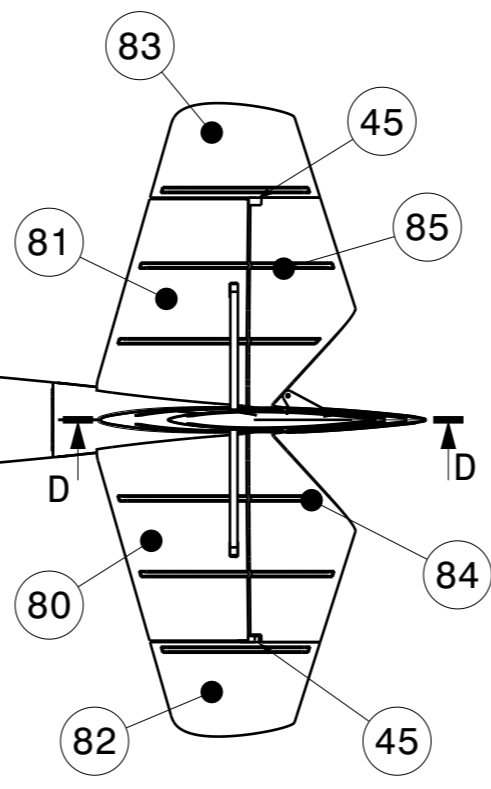
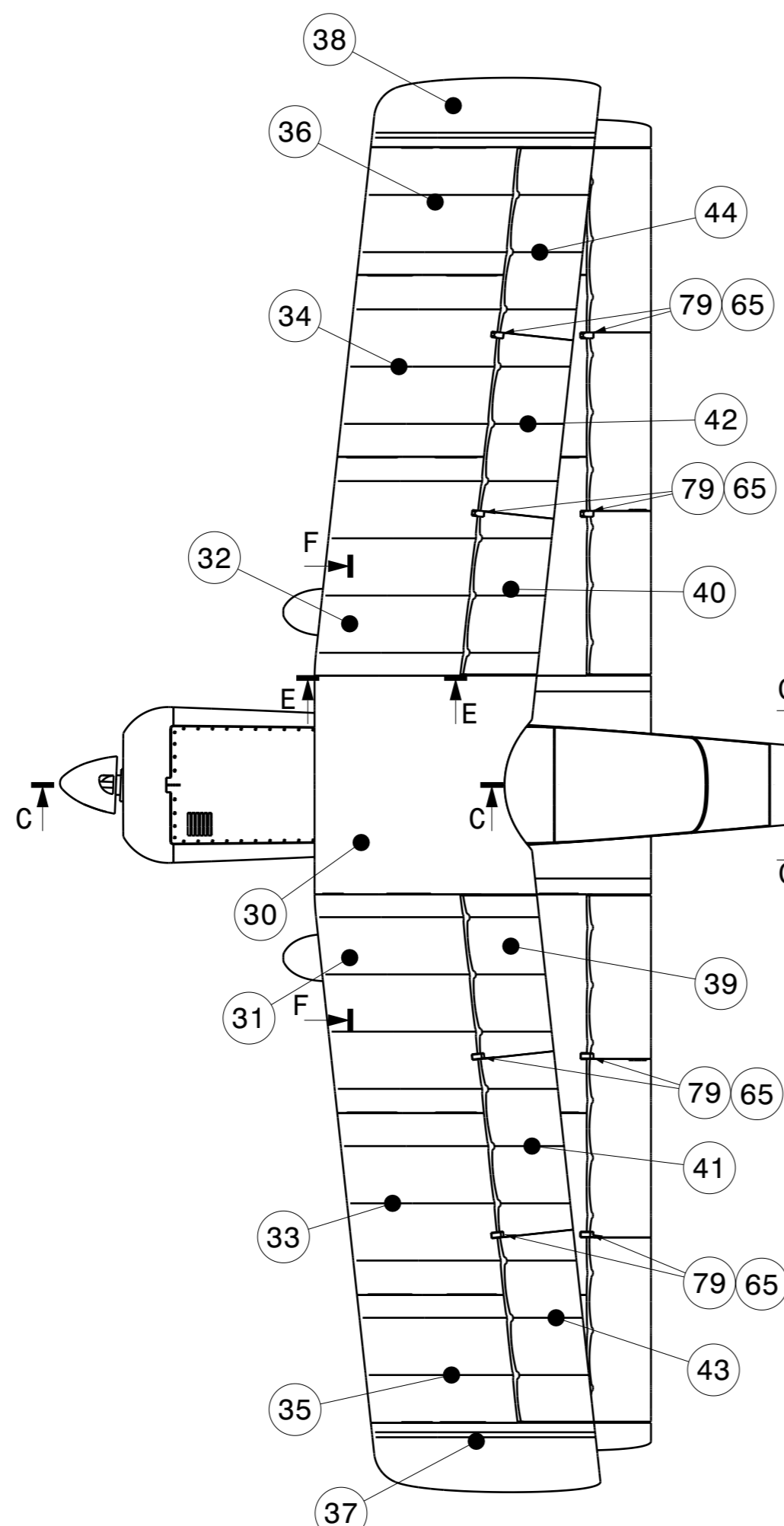

Section H-H

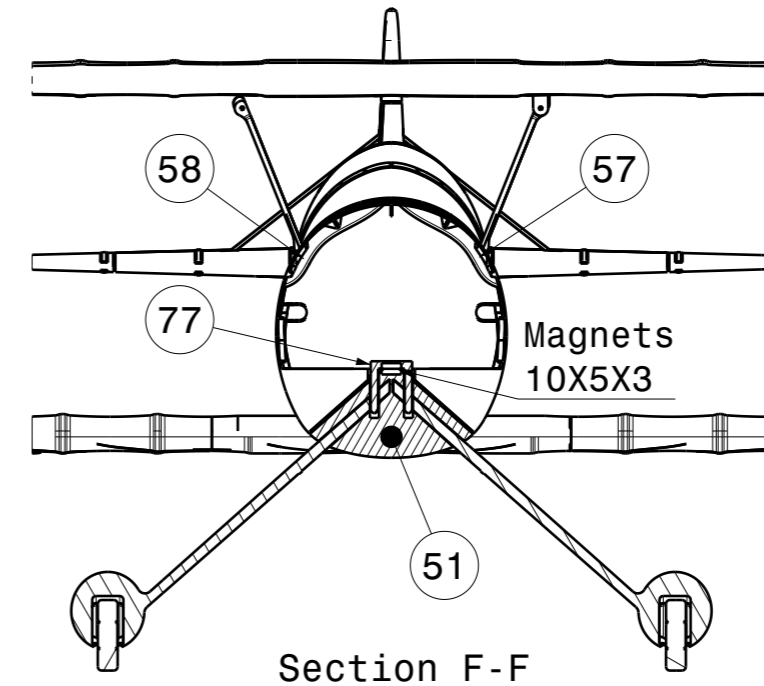

Section F-F

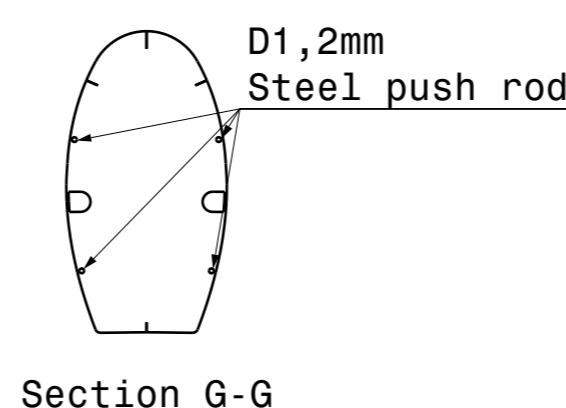

Section G-G

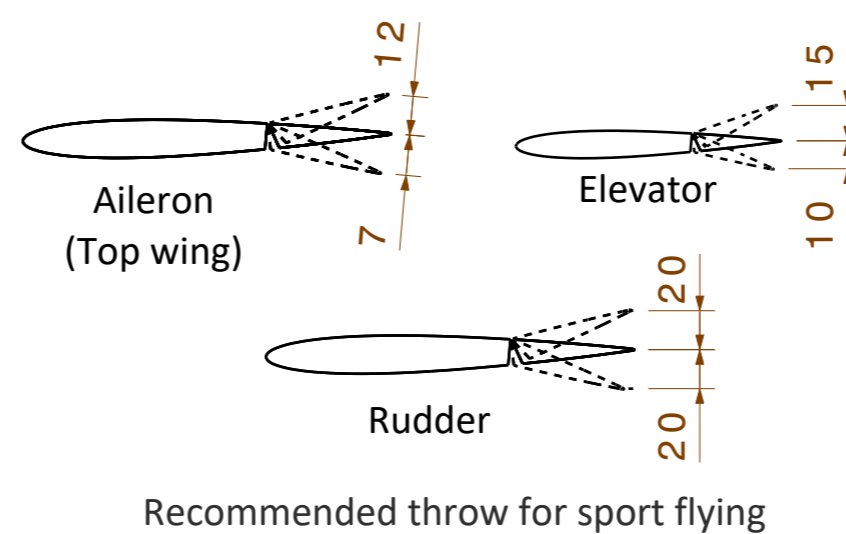

Recommended throw for sport flying

ITEM	NAME	CATEGORY
1	Spinner1	C
2	Spinner2	C
3	Fus1	C / C-LW
4	Canopy	A / A-LW
5	Fus2	A / A-LW
6	Fus3	A / A-LW
7	Fus4	A / A-LW
8	Fus5	A / A-LW
9	Fus6	A / A-LW
10	Fus6_servo	A / A-LW
11	Rudder_1	A / A-LW
12	Rudder_2	A / A-LW
13	Rudder_3	A / A-LW
14	VTP_1	A / A-LW
15	WingC_lower	A / A-LW
16	Wing1L_lower	A / A-LW
17	Wing1R_lower	A / A-LW
18	Wing2L_lower	A / A-LW
19	Wing2R_lower	A / A-LW
20	Wing3L_lower	A / A-LW
21	Wing3R_lower	A / A-LW
22	Wing4L_lower	A / A-LW
23	Wing4R_lower	A / A-LW
24	Aileron1L_lower	A / A-LW
25	Aileron1R_lower	A / A-LW
26	Aileron2L_lower	A / A-LW
27	Aileron2R_lower	A / A-LW
28	Aileron3L_lower	A / A-LW
29	Aileron3R_lower	A / A-LW
30	WingC_top	A / A-LW
31	Wing1L_top	A / A-LW
32	Wing1R_top	A / A-LW
33	Wing2L_top	A / A-LW
34	Wing2R_top	A / A-LW
35	Wing3L_top	A / A-LW
36	Wing3R_top	A / A-LW
37	Wing4L_top	A / A-LW
38	Wing4R_top	A / A-LW
39	Aileron1L_top	A / A-LW
40	Aileron1R_top	A / A-LW
41	Aileron2L_top	A / A-LW
42	Aileron2R_top	A / A-LW
43	Aileron3L_top	A / A-LW
44	Aileron3R_top	A / A-LW
X2	Elev_hinge	C
46	Elevator_fitting	C
X2	47 Wheel_fairing_front	A / A-LW
X2	48 Wheel_fairing_rear	A / A-LW
49	LG_L	C
50	LG_R	C
51	LG_Center	C
X2	52 RimD40	C
X2	53 TyreD40	C / C-LW
54	RimD25	C
55	TyreD25	C / C-LW
X2	56 Servo_holder_fus	C
57	Frame_front_L	C
58	Frame_front_R	C
59	Frame_rear_L	C
60	Frame_rear_R	C
X12	61 Strut_wing_fitting	C
62	Motor_holder_D28	C
63	Motor_holder_D35	C
64	Lock_canopy	C
X22	65 Axis_w_hole	C
66	Rudder_hinge_lower	C
67	Rudder_hinge_top	C
X2	68 Strut_wing	C / C-LW
69	Strut_L_fus	C
70	Strut_R_fus	C
X2	71 Strut_tail	C
72	Intake	C / C-LW
73	Exhaust	C / C-LW
X2	74 Servo_holder_wing	C
X2	75 Cover_horn	C
X3	76 Anchor_nut	C
77	LG_Pin	C
78	Engine	C
X8	79 Hinge_wing	C
80	HTP1L	A / A-LW
81	HTP1R	A / A-LW
82	Elev2L	A / A-LW
83	Elev2R	A / A-LW
84	Elev1L	A / A-LW
85	Elev1R	A / A-LW

- 10 The use of an impact resistant material like tough PLA is highly recommended
- 9 Add 6 top layers
- 8 Add 8 bottom layers
- 7 Add 2 bottom layers (parts marked with this flag note)
- 6 Print "tyres" with flexible material.
- 5 If your motor reach temperatures over 50 °C use ABS

4-Center of gravity can be moved up to 15mm rearward
2-Center of gravity marking placed under the top wing.

1- Red parameters are mandatory to ensure airplane functionality, assembly or weight target.

PRINTING PARAMETER	CATEGORY			
	A-LW	A	C-LW	C
Layer height (mm)	0.25	0,2	0,15	0,13
Bottom layers	0	0	4	4
Top layers	0	0	6	6
Wall lines / perimeter	1	1	2	2
Nozzle diameter (mm)	0,4	0,4	0,4	0,4
Material	LW-PLA	PLA/ PETG	LW-PLA/ LW-TPU	PLA/PETG FLEX/ABS
Infill density (%)	0	0	10	10
Printing temp (°C)	235	220	235	205 to 240
Bed temp (°C)	60	60	60	60
Flow (%)	53	100	53	100
Retraction (mm)	0,5 to 3	0,5 to 3	0,5 to 3	3
Retraction extra prime amount (mm)	0 to 0,7	0 to 0,7	0	0
Speed (mm/s)	55	50	35	25 to 50
Fan	YES	YES	YES	YES
Brim (mm)	3 to 5	3 to 5	0 to 3	0 to 3
Minimum layer time (s)	5	5	5	5
Support	NO	NO	NO	NO