

Section C-C

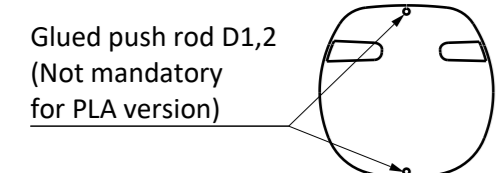

Section A-A

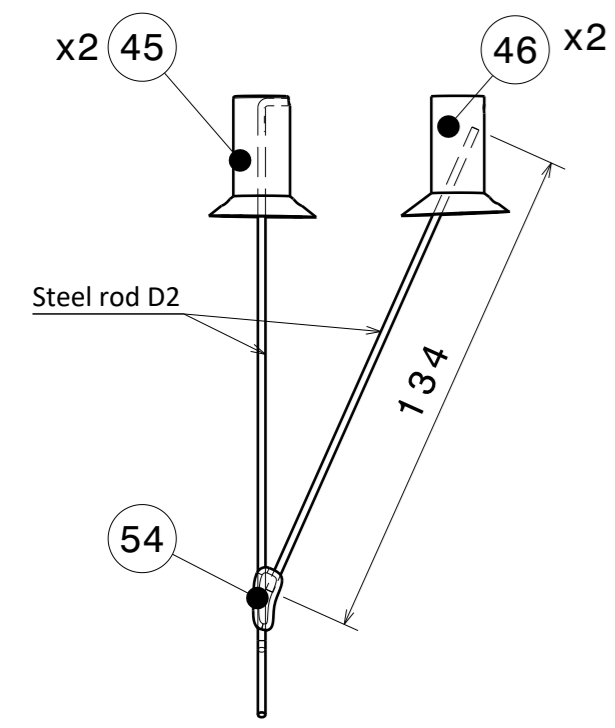
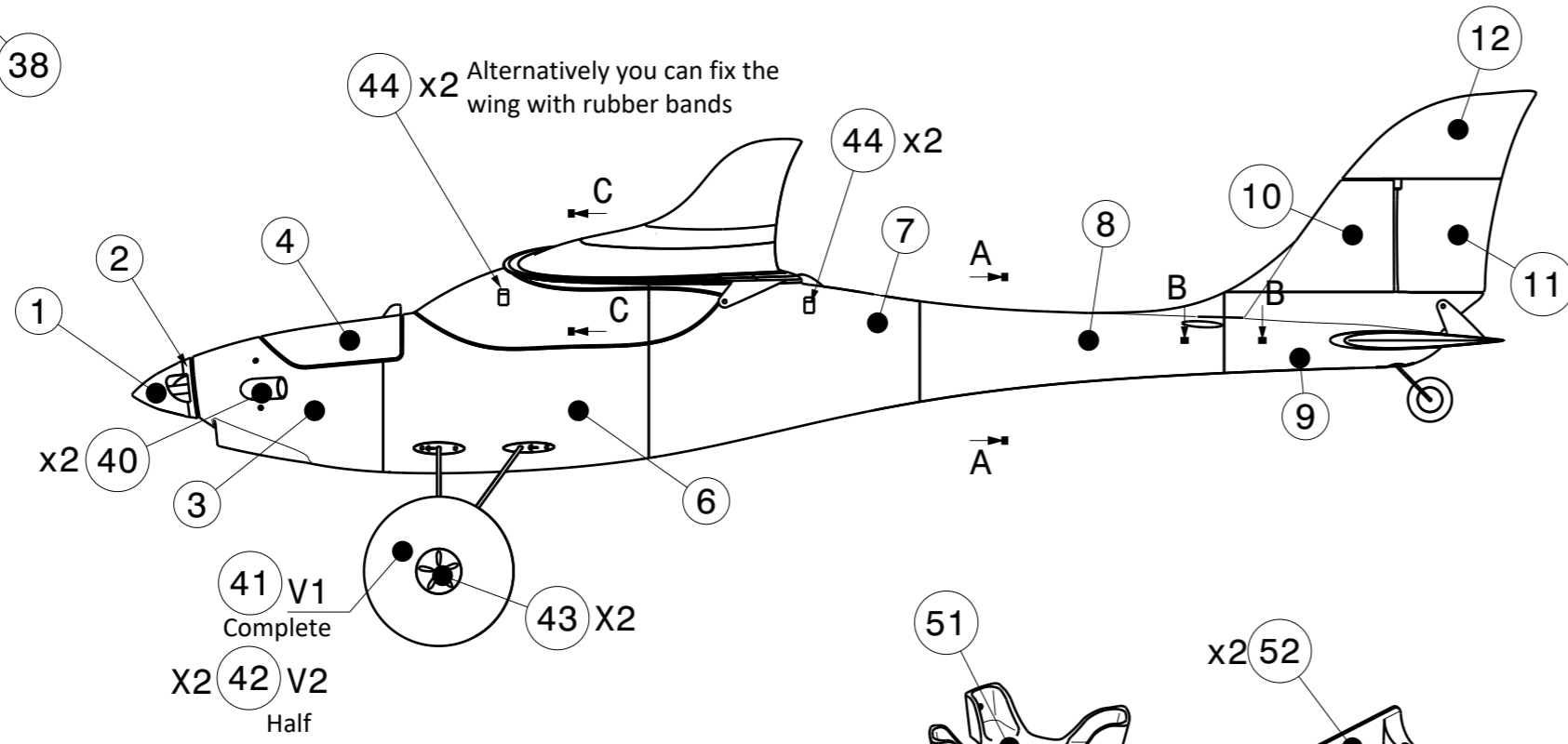

MAIN LANDING GEAR

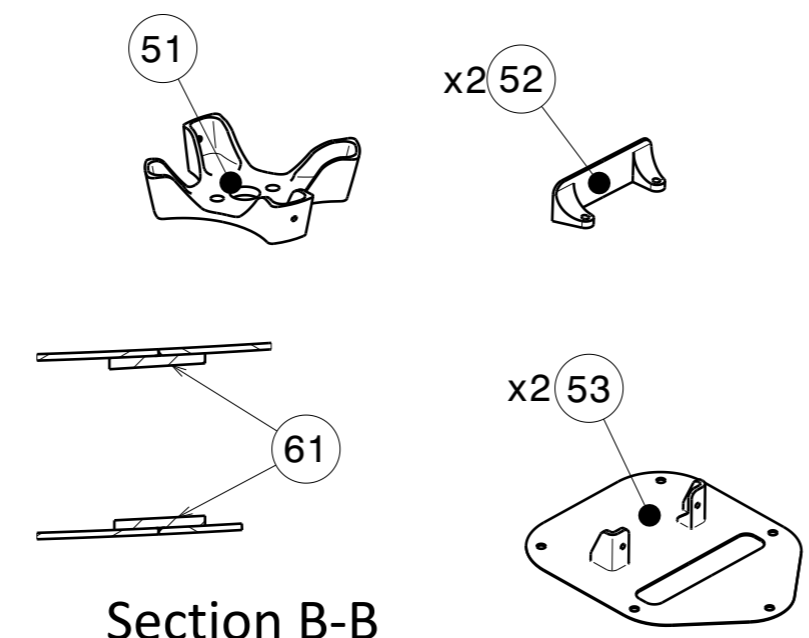

Section B-B  
(Concept valid also for join between WingC and Wing1R)

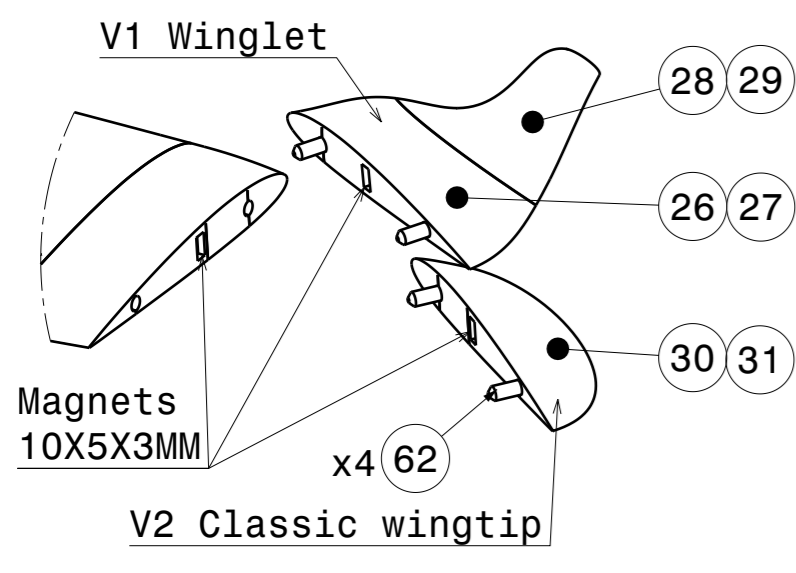

WINGTIP DETAIL

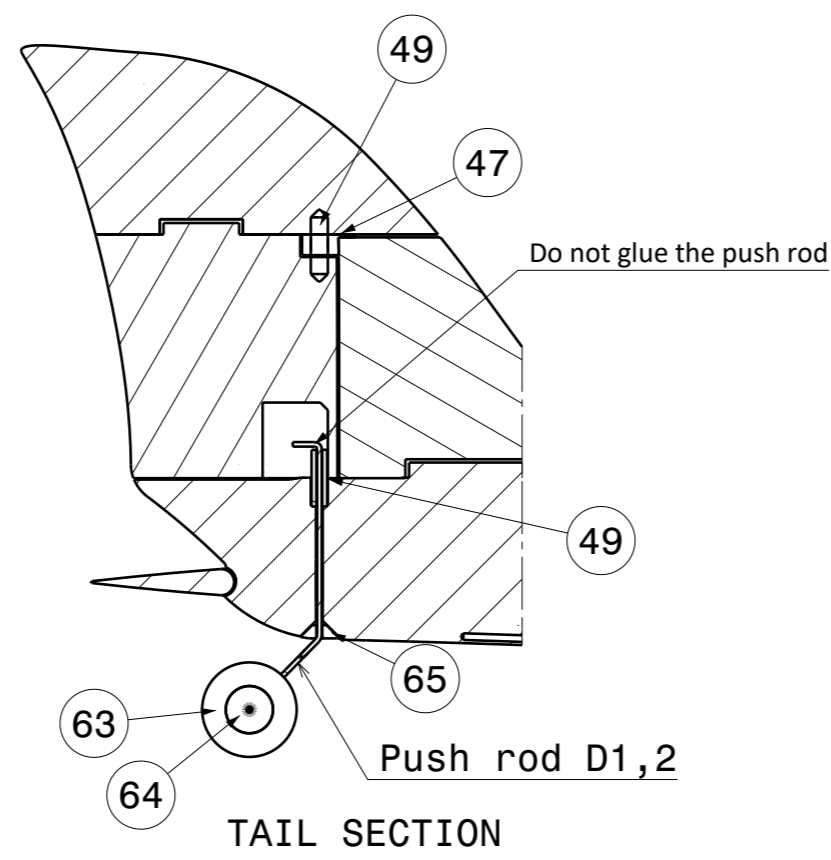

TAIL SECTION

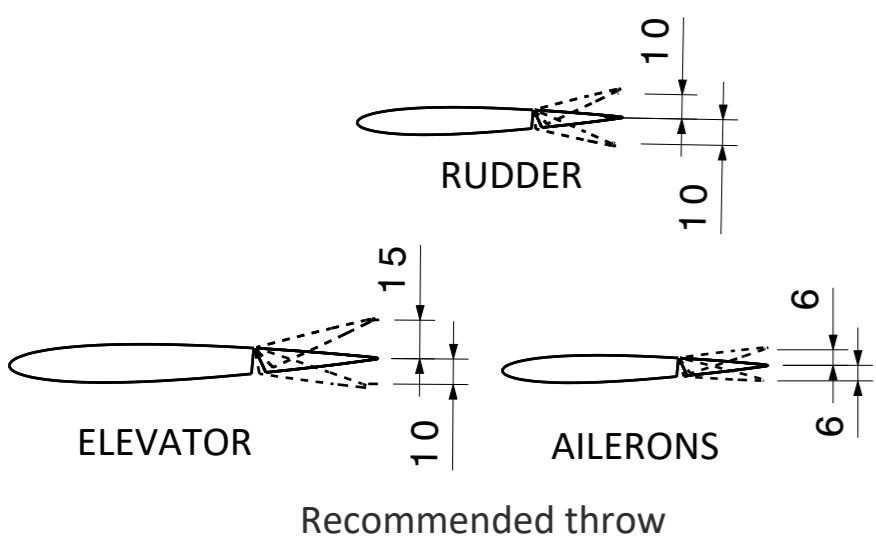

Recommended throw

- 9 Add 2 top layers
  - 8 Add 8 bottom layers
  - 7 Add 2 bottom layers (parts marked with this flag note)
  - 6 Print "tyre" with flexible material.
  - 5 If your motor reach temperatures over 50 °C use ABS or PETG for "Motor\_holder"
- 4-Center of gravity marking under the wing.  
 3-Do not print LW-PLA parts at the same time with others to avoid stringing in the outer surface.  
 2-Stringing can not be eliminated for LW-PLA material.  
 1-Red parameters are mandatory to ensure airplane functionality, assembly or weight target.

ITEM	NAME	CATEGORY
1	Spinner1	C
2	Spinner2	C
3	Fus1	A / A-LW
4	Canopy	A / A-LW
6	Fus2	A / A-LW
7	Fus3	A / A-LW
8	Fus4	A / A-LW
9	Fus5	A / A-LW
10	VTP	A / A-LW
11	Rudder_1	A / A-LW
12	Rudder_2	A / A-LW
13	Wing_C	A / A-LW
14	Wing1L	A / A-LW
15	Wing1R	A / A-LW
16	Wing2L	A / A-LW
17	Wing2R	A / A-LW
18	Wing3L	A / A-LW
19	Wing3R	A / A-LW
20	Flaperon_1L	A / A-LW
21	Flaperon_1R	A / A-LW
22	Flaperon_2L	A / A-LW
23	Flaperon_2R	A / A-LW
24	Flaperon_3L	A / A-LW
25	Flaperon_3R	A / A-LW
26	Winglet_1L	A / A-LW
27	Winglet_1R	A / A-LW
28	Winglet_2L	A / A-LW
29	Winglet_2R	A / A-LW
30	Wingtip_1L	A / A-LW
31	Wingtip_1R	A / A-LW
32	HTP1L	A / A-LW
33	HTP1R	A / A-LW
34	HTP2L	A / A-LW
35	HTP2R	A / A-LW
36	Elev1L	A / A-LW
37	Elev1R	A / A-LW
38	Anchor_nut_lower	C
39	Anchor_nut_top	C
40	Exhaust	C / C-LW
41	Tundra tyre	C / C-LW
42	Tundra tyre half	C / C-LW
43	Tundra_rim	C
44	Fitting_rubber	C
45	LG_root_front	C
46	LG_root_rear	C
47	Hinge_rudder	C
48	Hinge_wing	C
49	Axis_w_hole	C
50	Hinge_elev	C
51	Motor_holder	C
52	Servo_holder_fus	C
53	Servo_holder_Wing	C
54	LG_fitting	C
55	Wheel_fairing_1L	C / C-LW
56	Wheel_fairing_1R	C / C-LW
57	Wheel_fairing_2L	C / C-LW
58	Wheel_fairing_2R	C / C-LW
59	TyreD40	C / C-LW
60	RimD40	C
61	Guide	C
62	Pin	C
63	TyreD25	C / C-LW
64	RimD25	C
65	Tail_fitting	C
66	Wheel_fairing_3L	C / C-LW
67	Wheel_fairing_3R	C / C-LW

PRINTING PARAMETER	CATEGORY			
	A-LW	A	C-LW	C
Layer height (mm)	0,25	0,2	0,15	0,13
Bottom layers	0	0	4	4
Top layers	0	0	6	6
Wall lines / perimeter	1	1	2	2
Nozzle diameter (mm)	0,4	0,4	0,4	0,4
Material	LW-PLA	PLA/PETG	LW-PLA	PLA/PETG FLEX/ABS
Infill density (%)	0	0	10	10
Printing temp (°C)	235	220	235	205 to 240
Bed temp (°C)	60	60	60	60
Flow (%)	53	100	53	100
Retraction (mm)	0,5 to 3	0,5 to 3	0,5 to 3	3
Retraction extra prime amount (mm)	0 to 0,7	0 to 0,7	0	0
Speed (mm/s)	55	50	35	25 to 50
Fan	YES	YES	YES	YES
Brim (mm)	3 to 5	3 to 5	0 to 3	0 to 3
Minimum layer time (s)	5	5	5	5
Support	NO	NO	NO	NO